

SCHLAGE

RC Pure IPT™
multi-technology
reader controller

User guide



FCC Statement

Model	FCC ID	IC ID
RC11	XPB-RC11	8053B-RC11
RC15	XPB-RC15	8053B-RC15
RCK15		

This device complies with Part 15 of the FCC Rules.

Operation is subject to the following two conditions:

- (1) This device may not cause harmful interference, and
- (2) This device must accept any interference received, including interference that may cause undesired operation.

Changes or modifications not expressly approved by the party responsible for compliance could void the user's authority to operate the equipment.

This equipment has been tested and found to comply with the limits for a Class B digital device, pursuant to part 15 of the FCC Rules. These limits are designed to provide reasonable protection against harmful interference in a residential installation. This equipment generates, uses, and can radiate radio frequency energy and, if not installed and used in accordance with the instructions, may cause harmful interference to radio communications. However, there is no guarantee that interference will not occur in a particular installation. If this equipment does cause harmful interference to radio or television reception, which can be determined by turning the equipment off and on, the user is encouraged to try to correct the interference by one or more of the following measures:

- (1) Reorient or relocate the receiving antenna.
- (2) Increase the separation between the equipment and receiver.
- (3) Connect the equipment to an outlet on a circuit different from that to which the receiver is connected.
- (4) Consult the dealer or an experienced radio/TV technician for help.

This device complies with RSS-210 of Industry Canada.

Operation is subject to the following two conditions:

- (1) This device may not cause harmful interference, and
- (2) This device must accept any interference received, including interference that may cause undesired operation.

Le présent appareil est conforme aux CNR d'Industrie Canada applicables aux appareils radio exempts de licence. L'exploitation est autorisée aux deux conditions suivantes:

- (1) l'appareil ne doit pas produire de brouillage, et
- (2) l'utilisateur de l'appareil doit accepter tout brouillage radioélectrique subi, même si le brouillage est susceptible d'en compromettre le fonctionnement.

This Class B digital apparatus complies with Canadian ICES-003.

Cet appareil numérique de la classe B est conforme à la norme NMB-003 du Canada.

For RF Safety and per FCC and Industry Canada regulations, the product should never be installed within 8-inches (20cm) of typical people locations.



U.S. Patent Nos.

7,775,429

8,662,386

9,153,083

9,336,633

7,676,839

U.S. Application No.

14/019,924

Contents

- ii FCC Statement
- iv Contact information
- iv Warnings and cautions

5 Before you begin

- 5 General requirements
- 6 Reader controller specifications
- 7 Installation location guidelines
- 9 Reader controller reset button

10 Wiring

- 10 Powering the reader controllers
- 11 Door wiring
- 13 Lock wiring using PoE
- 13 Door sensor wiring
- 14 Advanced Security Module (ASM) wiring

15 Configuring communications

- 15 Reader controllers to host software

16 Appendix A: Power options

- 16 PoE Power Budget Calculations
- 17 Additional power options
- 18 Dual power sources

19 Appendix B: Additional wiring considerations

- 19 ASM LED status index
- 19 Wiring two readers to one lock
- 20 Managing inductive load challenges
- 21 PoE: Magnetic lock, ASM and PIR

22 Appendix C: UL Disclaimers

Contact information

If you need assistance, contact technical support at:

1-877-671-7011

www.allegion.com/us

MIFARE® and DESFire™ are registered trademarks of NXP B.V.

Warnings and cautions

WARNING

Warnings indicate potentially hazardous conditions, which if not avoided or corrected, may cause death or serious injury.

CAUTION

Cautions indicate potentially hazardous conditions, which if not avoided or corrected, may cause minor or moderate injury. Cautions may also warn against unsafe practices.

NOTICE

Notices indicate a condition that may cause equipment or property damage only.

Before you begin

This guide discusses each wiring process separately. Understanding all of these processes makes a project much simpler and helps guarantee success. To install a Reader Controller unit, you must complete four key tasks:

1. **Mount the Reader Controller in the appropriate location.** Recommended locations and wiring methods shall be in accordance with 1) the National Electrical Code, {ANSI/NFPA 70}; 2) International Building Code {IBC}, and 3) Americans with Disabilities Act {ADA}.
2. **Supply power to the Reader Controller.** This may be accomplished with power being provided on the Ethernet data cable (Power over Ethernet [PoE / PoE+ / IEEE 802.3af]) or through an external DC power source (12VDC). When powering from PoE or PoE+, in order for the system to be UL294 V7 compliant, the Power Sourcing Equipment (PSE) injector or end point must be compliant to UL294 or UL294B standards.
3. **Wire the unit to the door's locks and other components for physical access control.**
4. **Connect the unit to the data network for communication with the host access control system.**

The Reader Controller complies with UL 294 V6 and is rated for the following performance levels:

Standby power	Level I
Endurance	Level IV
Line Security	Level I
Destructive Attack	Level I (ASM required)

General requirements

- If PoE is not being used, then use only UL-listed, access control, power-limited power supplies with an 'AC on' indicator light clearly visible on the enclosure. Power supplies should provide at least four hours of standby power.
- Never connect power supplies to a switch-controlled receptacle.
- Install the Schlage system in accordance with the National Electrical Code NFPA 70, IBC, and ADA requirements, or the Canadian Electrical Code, C22.1-02. (Local authority has jurisdiction.)
- Use only UL-listed wire or cabling recognized suitable for Schlage power supply and data communications, in accordance with the National Electrical Code.
- Where possible, separate Schlage equipment and cabling from sources of electromagnetic interference (EMI). Where this is not possible, take other steps to reduce the effect of EMI on cabling or equipment.
- Protect input and output terminals adequately from transient signals. Also, connect these terminals to power-limited circuitry.
- The readers are UL Listed for standalone operation only. Reference to operation with the server have not been investigated by UL.
- Operation with the ASM has not been investigated by UL.
- Accessories connected to the readers shall be UL Listed.
- The reader controllers are intended to be used with the building's communication system and not intended for direct outside connection.
- All input/output wiring shall employ earth grounded shielded cable. The maximum wiring distance is 30 m, same room.
- The minimum conductor gauge permitted to connect between the PSE or power injector and the device shall be 26 AWG (0.13 mm²) for patch cords; 24 AWG (0.21 mm²) for horizontal or riser cable.
- Premise network equipment shall be UL Listed for compliance with UL60950-1 or UL62368-1.
- Intended for Alternative A PoE sources. NEC, Class 3 wiring methods shall be followed.
- Compliance to ULC-S319, Electronic Access Control Systems, would be invalidated through the use of any add-on, expansion, memory or other module manufactured or supplied by the manufacturer or manufacturer's representative.
- In POE applications, installation shall be in accordance with Article 725.121, Power Sources for Class 2 and Class 3 circuits.

Reader controller specifications

Model	RC11	RC15	RCK15
Reader controller Type	Mobile enabled multi-technology		Mobile enabled multi-tech w/keypad
Mounting Style	Mullion	Single Gang	
Standards	ISO 14443A, ISO 15693		
Certifications	FCC Certification, IC Certification, UL 294/cUL Listed, RED Directive, CE Mark, IP65, REACH, Bluetooth SIG, RoHS3		
Frequency	2.4 GHz, 13.56 MHz and 125 kHz		
Technology Supported (See Appendix C: UL Disclaimers on page 22.)			
CSN	✓	✓	✓
Proximity	✓	✓	✓
Smart	✓	✓	✓
Mobile (NFC)	✓	✓	✓
Mobile (Bluetooth)	✓	✓	✓
Read Range			
Prox FSK	Up to 1.75" (4.4 cm)	Up to 4.0" (10.1 cm)	Up to 4.0" (10.1 cm)
Prox ASK	Up to 1.5" (3.8 cm)	Up to 3.25" (8.2 cm)	Up to 3.25" (8.2 cm)
MIFARE Classic EV1	Up to 1.75" (4.4 cm)	Up to 2.0" (5.1 cm)	Up to 2.0" (5.1 cm)
MIFARE Plus	Up to 0.25" (0.6 cm)	Up to 1.25" (3.2 cm)	Up to 1.25" (3.2 cm)
MIFARE DESFire EV1	Up to 0.5" (1.3 cm)	Up to 1.5" (3.8 cm)	Up to 1.5" (3.8 cm)
MIFARE DESFire EV2	Up to 1.5" (3.8 cm)	Up to 2.0" (5.1 cm)	Up to 2.0" (5.1 cm)
Schlage Mobile Credential (Bluetooth) (short range-standard)	5' (1.5 m)		
Schlage Mobile Credential (Bluetooth) (long range-optional)	30' (9.1 m)		
Users	64,000		
Audits	5,000		
Schedules	32		
Holidays	32		
Auto Events	448		
Communication Standards	10/100 Mbps, Half or Full Duplex Ethernet, WebSockets, Standard Cat5e or better Cable DHCP Addressing Supported Transport Layer Security (TLS) version 1.2 Advanced Encryption Standard (AES), 256-bit		
Power Options	Power Over Ethernet (PoE/PoE+), (IEEE 802.3af/at) DC Power: 12VDC +/- 10% at 300 mA ➔ PLEASE NOTE: 300 mA current rating does not include locking mechanism current. Consult your product documentation.		
Outputs	Locking mechanism: 600 mA @ 12VDC max Advanced Security Module Outputs RS-485 (future use) 2x General Purpose Outputs (TTL logic levels at ± 24mA)		
Signal Inputs	Door Position Switch (DPS) Request to Exit (REX) Auxiliary Input (AUX)		
Operating Temperature	-31°F (-40°C) to 151°F (66°C)		
Dimensions	5.94" x 1.77" x 1" (150 x 45 x 25 mm)	5.13" x 3.25" x 1" (130 x 83 x 25 mm)	

Installation location guidelines

When selecting the location where you are going to mount the Reader Controller, a few guidelines should be observed.

1. In humid environments, a drip-loop should be formed in the Reader Controller's cables, before the cables enter the unit.
2. The Reader Controller should be protected from extreme heat and sunlight. It is rated for conditions up to 151 F. A direct southern exposure, in the Southwest area of the United States may exceed these ratings.
3. The cables extending from the back of the Reader Controller's field wiring cable is available in a two standard lengths (10' or 25' [3 m or 7.62 m]). The door wiring must terminate within that distance or less than 98' (30 m) from the Reader Controller.
4. The wall mounting templates are shown in **Figure 1.1: RC11 Mounting** and **Figure 1.2: RC15/RCK15 Mounting**.
5. The selected location should meet ADA requirements. Check local regulations for more information.

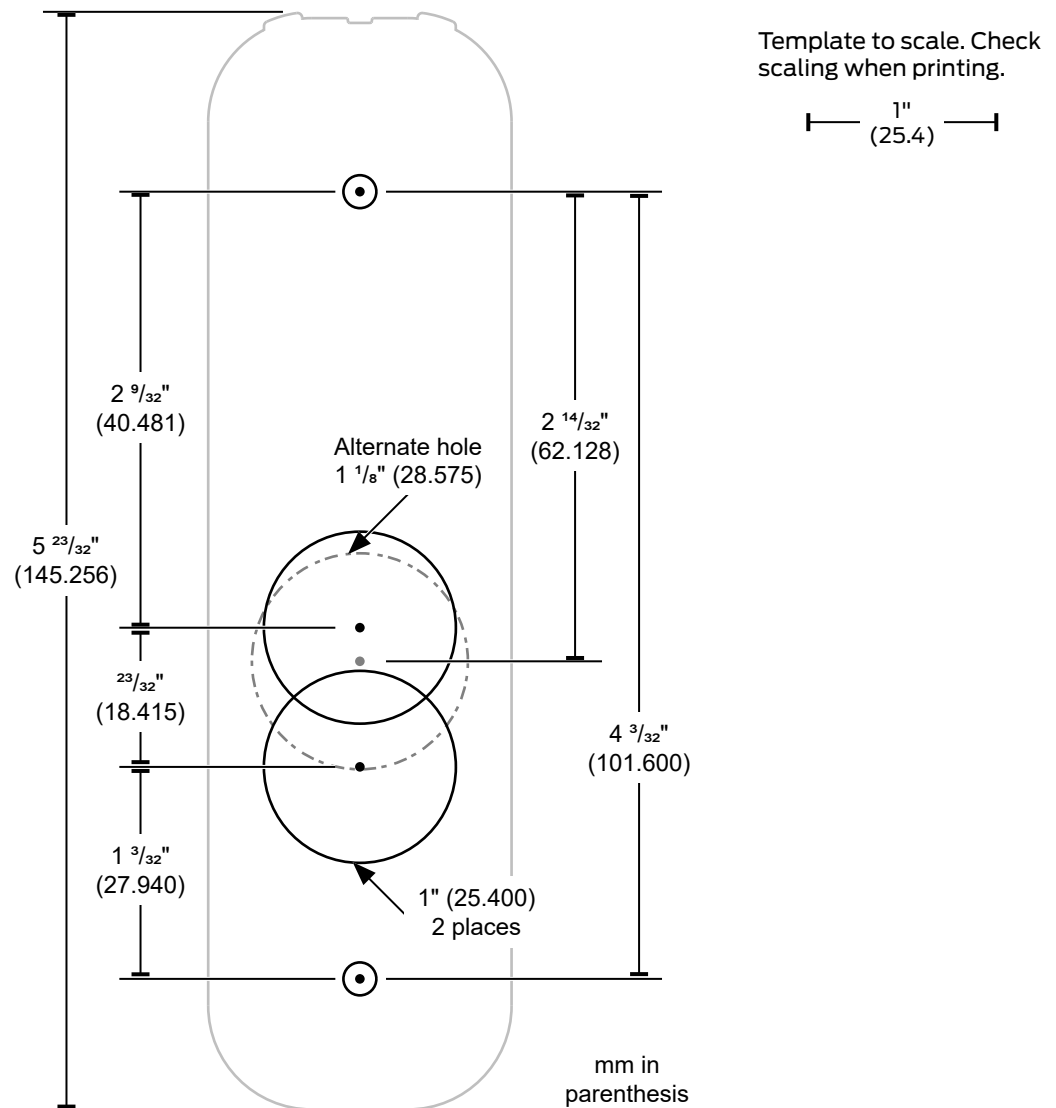

Figure 1.1: RC11 Mounting

Before you begin | Installation location guidelines

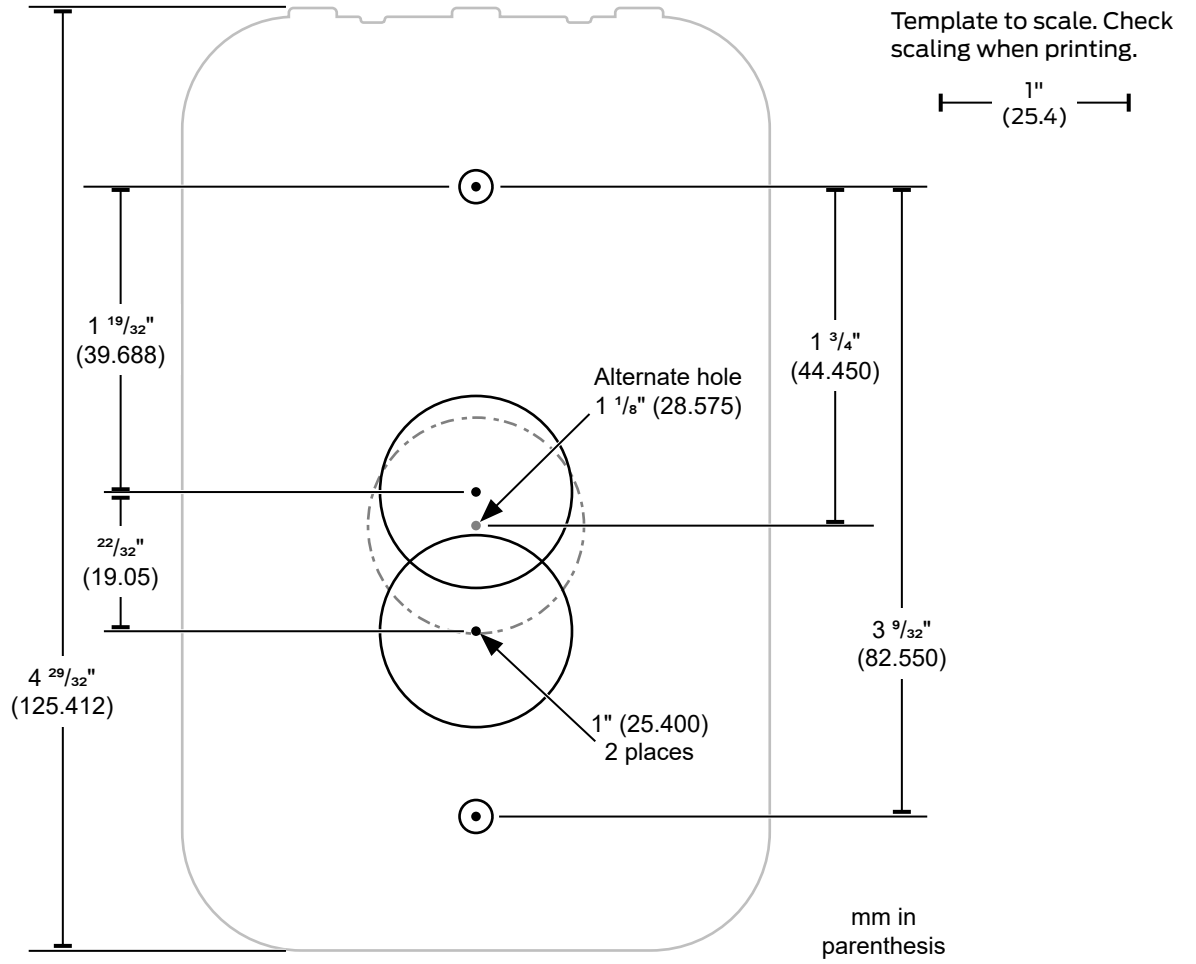

Figure 1.2: RC15/RCK15 Mounting

Reader controller reset button

The reset button is located on the back of the Reader Controller. It can be used for two different types of resets.

- The Reader Controller must be connected to the network before initiating reset.

Network reset

Press and hold the reset button until one green LED flash and one short beep, (approx. five secs.) then release. Successful network reset is indicated by one LED flash and one short beep. A network reset reestablishes the network connection using the current network settings. The certificate file and domain routing information is reestablished prior to reforming the connection to the host access control system.

Factory default reset

Press and hold the reset button until two green LED flashes and two beeps (approx. 10 secs.), then release. Successful factory default reset is indicated by a long steady green light and long beep. A Factory Default Reset (FDR) will return the Reader Controller settings to the original settings as shipped from the factory. Removes configurations, databases, and requires the lock to be re-captured.

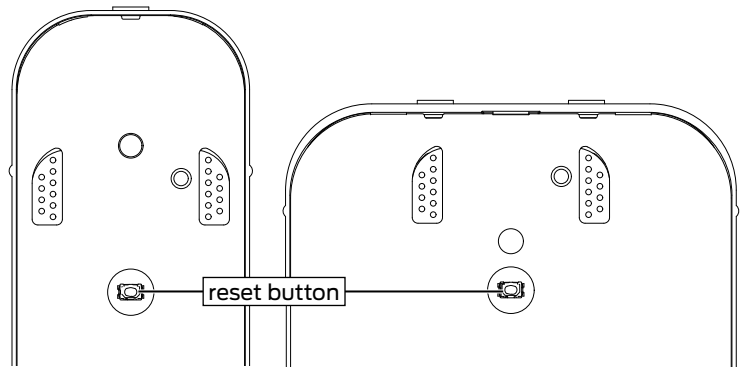

Figure 1.3: Reset button locations

Table 1.1: Reader reset indications		
Actions	Lights	Beeps
Factory Default Reset (FDR) initiated	2x green short	2x short
Network reset initiated	1x green short	1x short
Reset complete	1x green long	1x long
Reset failed	2x red long	2x long

Wiring

Powering the reader controllers

- A direct connection to a power source is required.
- Reader controllers can be powered with 12 volts DC or PoE (IEEE 802.3af) power and the supply must be regulated.

NOTICE

Never connect 24VDC to the Reader Controller. 24V will damage the device and will void the unit's warranty.

Power over ethernet (PoE) option

PoE allows one cable to supply data and power to the Reader Controller, which in turn can then supply 12VDC to the door's electronic lock.

If your network switches do not support PoE, then a PoE Injector can be used to augment the switch's output with PoE power. A PoE injector is normally located close to your existing network hub/switch, and the PoE Injector itself is plugged directly into a standard AC outlet, or for extra reliability, a UPS with battery backup.

A standard CAT5/6 cable is then run between the PoE source (Injector or switch) and the Reader Controller which will be located right next to the door. The CAT5/6 cable can be up to 100 Meters (328 feet) long, including all patch cables and patch panels.

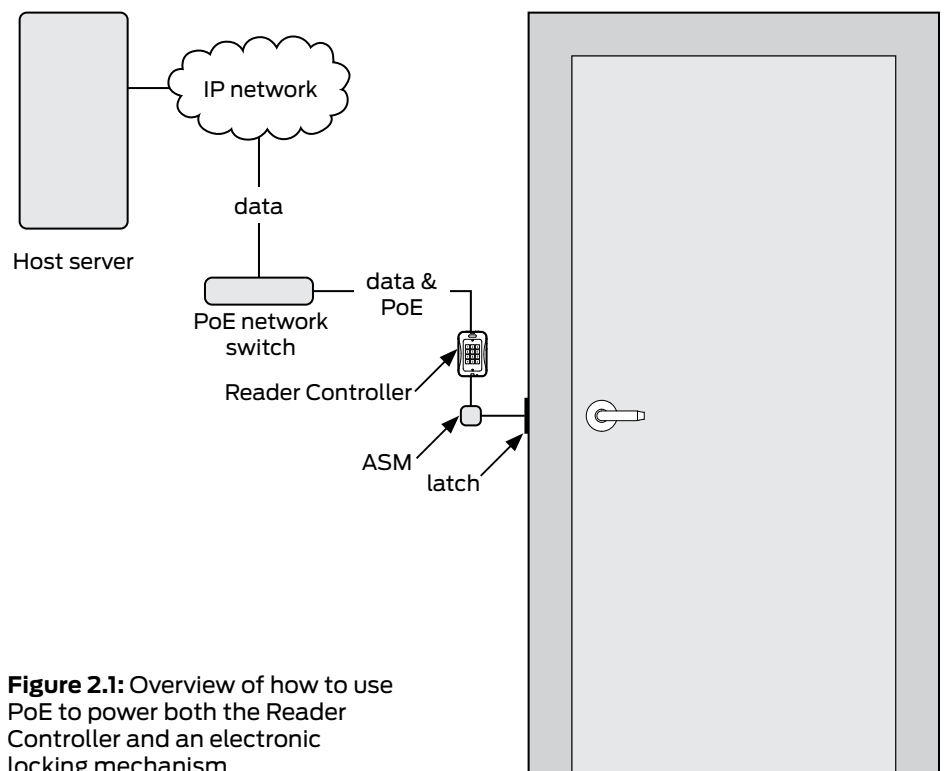

Supplying 12 VDC to door components from the PoE powered Reader Controller

When the Reader Controller is powered by PoE, the reader can supply 0.6 amps @12 VDC power for external components. This DC power is available via two field wiring wires.

The red field wiring is typically used to control the door's lock. The red wire's 12VDC output will be activated/deactivated when the reader is operating the door's lock. This connection has a built-in current limiting feature to prevent the lock from consuming too much power.

The orange field wiring provides a source of continuously-available 12VDC power for other desired devices.

Figure 2.1: Overview of how to use PoE to power both the Reader Controller and an electronic locking mechanism

Door wiring

➔ Door wiring should be done before power is connected to every Reader Controller.

Example devices:

- Electronic door latch
- Request to exit (REX) devices like a REX button or motion detector
- Door sensors
- **Figure 2.2: Typical configuration of equipment at the door**

Reader controller control-leads

Field wiring consists of 12 wire leads (22AWG) which are used to connect to the various components at the door location. Most installations do not require the use of all the leads. The usage of each available lead is shown in **Figure 2.3: Reader controller field wiring color codes**.

The controllers have a lock-control circuit. This circuit provides conditioned 12VDC power up to 600mA and can be directly connected to the electronic lock to unlock the door when a valid credential is presented.

The usage of each lead will be detailed in the next few pages.

➔ Field wiring cable length must remain under 98' (30 m).

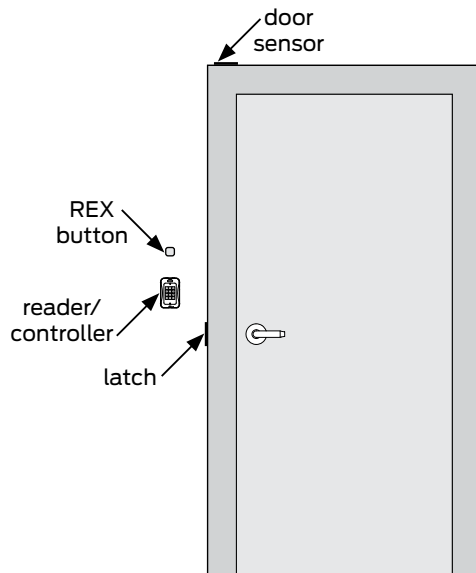

Figure 2.2: Typical configuration of equipment at the door

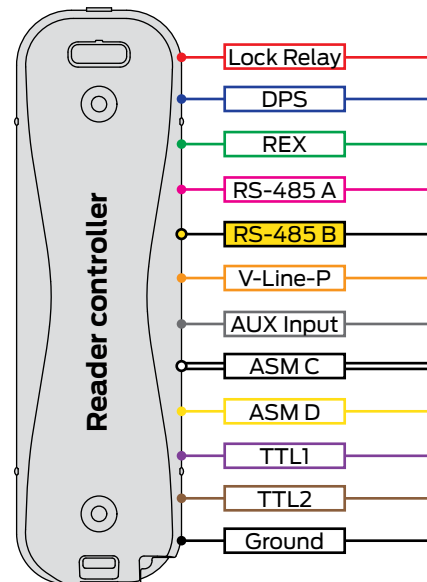

Figure 2.3: Reader controller field wiring color codes

Name		I/O	Pin	Wire Color	Description
Lock	Lock Output	Output	1	Red	The lock output is capable of providing up to 600 mA at 12 VDC to a resistive load.
DPS	Door Position Switch	Input	2	Blue	When a DPS is installed, the RC will trigger an alert, forced door or propped door, and can be configured to activate the TTL output(s).
REX	Request to Exit	Input	3	Green	When the switch activates, the RC will audit the event and activate the Lock Relay, and/or TTL(s) if configured. REX can be configured active high or active low through configuration settings.
RS-485 A	RS-485 Data A	Both	4	Pink	Future intent RS-485 Data A communication.
RS-485 B	RS-485 Data B	Both	5	Yellow/Black	Future intent RS-485 Data B communication.
V-Line-P	12V Input/Output	Either	6	Orange	12 VDC input. When POE powered, 12 Vdc output at 100mA max.
AUX	Auxiliary Input	Input	7	Gray	When the switch activates, the RC will audit the event and activate the Lock Relay, and/or TTL(s) if configured. AUX can be configured active high or active low through configuration settings.
ASM D	Advanced Security Module Data	Output	8	Yellow	Advanced Security Module data communications.*
ASM C	Advanced Security Module Clock	Output	9	White	Advanced Security Module clock communications.*
TTL1	Generic Logic Output 1	Output	10	Purple	Generic output at TTL voltage levels. Capable of sinking or sourcing up to 24 mA. TTL can be configured to activate based on various sources including the lock relay, REX, AUX, and DPS. TTL can be configured active high or active low through configuration settings.
TTL2	Generic Logic Output 2	Output	11	Brown	Generic output at TTL voltage levels. Capable of sinking or sourcing up to 24 mA. TTL can be configured to activate based on various sources including the lock relay, REX, AUX, and DPS. TTL can be configured active high or active low through configuration settings.
Ground	Ground	Ground	12	Black	Electrical ground for the RC.

* Not investigated by UL.

Lock wiring using PoE

The Reader Controller supports a simplified configuration when PoE is being used to supply the lock's power.

1. Connect the red wire on the Reader Controller to the positive lead of the electric lock. See **Figure 2.4: Typical fail-secure door lock wiring**
2. Connect the negative lead of the lock to the black wire on the Reader Controller.
3. See **Managing inductive load challenges** on page 20 for more info regarding the use of the BackEMF diode.

Door sensor wiring

Connecting the Reader Controller to a door sensor allows the host access control system to detect if the door is ajar. Then the host access control system can create alarms based on the door's state.

First, connect one terminal of the door sensor to the reader's blue wire. Then connect the door sensor's other terminal to the Reader Controller's common ground wire (black).

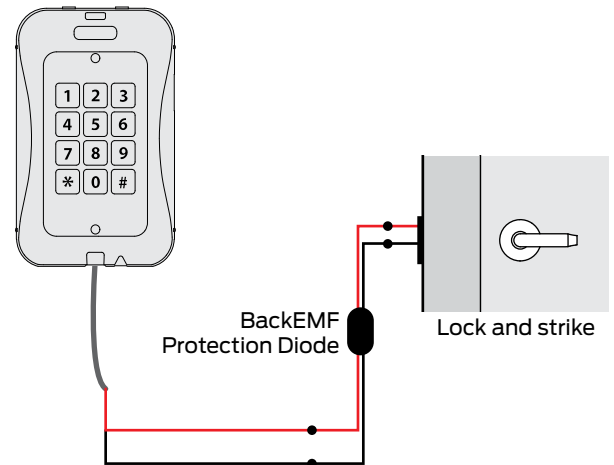

Figure 2.4: Typical fail-secure door lock wiring

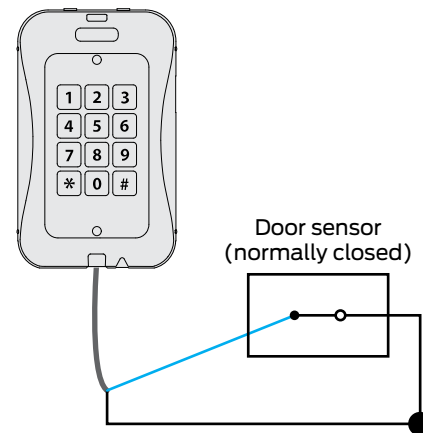

Figure 2.5: Door sensor wiring

Advanced Security Module (ASM) wiring

The Reader Controller has an optional ASM, which allows you to isolate the door's lock control circuitry on the secure side of the building.

The ASM contains a form-C relay with dry-contacts that are rated for 3 amps of current @ 30 Volts. It can also be used in cases where the Reader Controller is switching an externally supplied voltage or an external control signal. Examples of such usages include operating a 24VDC lock, or switching a logic signal for a garage door opener.

Two methods of connecting the ASM are shown. **Figure 2.6: ASM with Reader Controller supplying PoE power** shows powering both the lock and the ASM with the Reader controller's PoE power. **Figure 2.7: ASM with lock running on 24V external power** shows powering the ASM with the Reader controller's PoE power output, and the lock with an external 24 volt power supply.

ASM Wire Conductor Preparation:

Strip back the wire insulation: 0.25" to 0.281" (6 mm to 7 mm).

Acceptable single conductor sizes: 26 gauge to 15 gauge

Acceptable two conductors sizes: 26 gauge to 15 gauge

➔ Note for multi-stranded conductors: Avoid allowing any stray wire strands from contacting the adjacent terminal block connection.

Twist the multi-strands together prior to insertion. Lightly solder-tinning the exposed wire can help prevent stray strands.

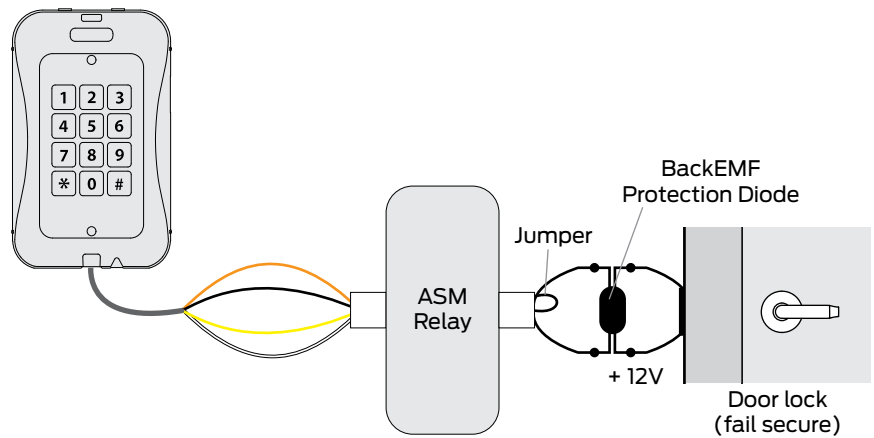

Figure 2.6: ASM with Reader Controller supplying PoE power

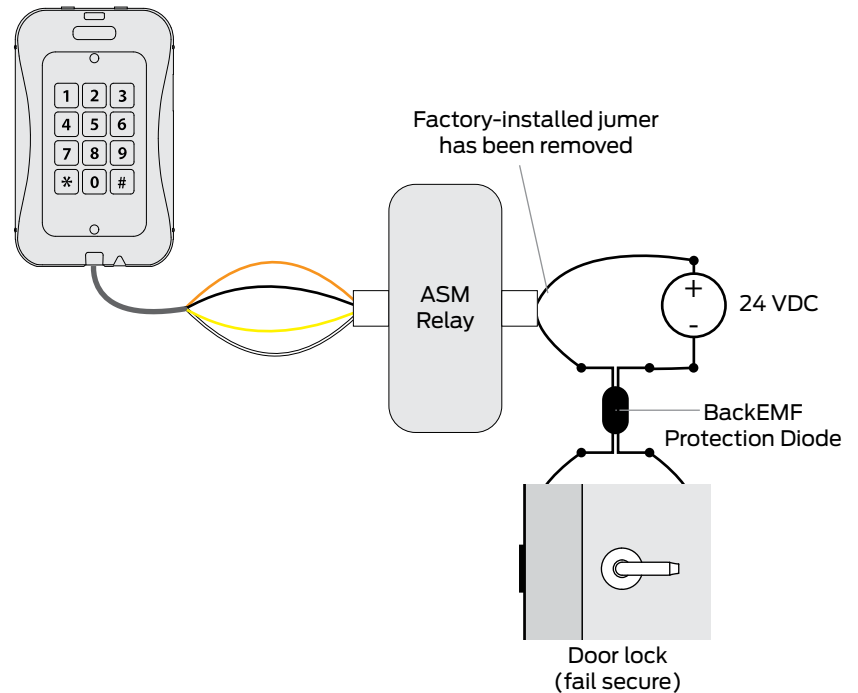

Figure 2.7: ASM with lock running on 24V external power

Reader Side Connection		Lock Side Connection		
Label	Wire	Label	PoE Power (Figure 2.6)	24V Power (Figure 2.7)
A	Orange (12 V input power)	1	12V output power	not used (factory-installed jumper removed)
B	Black (ground)	2	Power ground	not used
C	Yellow	3	ASM common contact	
D	White	4	ASM normally closed (NC) contact (fail-safe lock)	
		5	ASM normally open (NO) contact (fail-secure lock)	

Configuring communications

The Reader Controller can communicate with a variety of access control software platforms. Contact your sales associate for a complete list. The reader controllers communicate over the network to the host system. Below are best practices on this configuration.

Reader controllers to host software

- ➔ Many other Ethernet network topology permutations exist. This is the most common Ethernet configuration used by Schlage customers.

This is the simplest type of network connection. The Reader Controller is an IOT-style device that requires minimal network configuration to function. The physical access control partner's host system provides a cloud instance of the host software. The reader controllers must be configured to connect to host software. The MAPP¹ provides the interface to capture and commission a unit with the initial configurations required to connect to the host software. The following configurations are needed to direct the Reader Controller to connect to the host software:

- ➔ Notice: Prior to capturing and commissioning, the reader controlled must be fully installed in its intended location (including cover).
- WebSocket Server URL
- Certificate Authority Server URL

Addressing: The recommended best-practices is to let the local network's DHCP service assign the IP Address to each reader. As an alternate, you can manually assign the reader's IP Address. To allow the reader to successfully reach the host software, the following setting are required:

- Static IP Address that is valid on the local subnetwork
- IP Address of the local subnetwork's gateway.
- Subnet Mask
- DNS server's IP Address
- Alternate DNS server's IP Address

Here are a couple guidelines to follow to assure that your network's configuration will support the Schlage access system.

- The Reader Controller is a standard "network appliance." Standard TCP/IP networking rules apply.
- DHCP Configuration
 - If the reader controllers are to be left on DHCP it is strongly recommended to use reservations, so the IP address does not need to be renewed.
- Network Configuration
 - A common best-practice is to place the reader controllers in a dedicated subnet
 - The PoE switch should have enough power to run all ports and account for in rush. (IE. A switch restart which would cause all readers to restart.)

¹ Mobile application. This is the application used to control access to the lock.

Appendix A: Power options

PoE Power Budget Calculations

When planning an installation using PoE, you need to validate that the PoE source (PoE Injector or PoE equipped Network Switch) supplying the PoE power is sized properly for all the attached PoE devices. To do this, you total up the power draw (in watts) of the PoE connections, and compare that total power draw to the rated capacity of the PoE source.

When the Reader Controller is dual powered there may be an increased number of power audits. If the 12VDC regulated power supply voltage fluctuates above 12.1VDC the Reader Controller will transition from the PoE source to the DC power supply, resulting in an audit.

Likewise when the DC power supply drops below 12.1VDC the Reader Controller will transition from the DC power supply to the PSE, resulting in another audit.

Door Location Configuration	PoE Power Requirement *
Reader controller	2.65 W
Reader controller with Electronic Lock (300 mA @ 12V)	6.26 W
Reader controller with Electronic Lock (600 mA @ 12V)	9.85 W
* Ethernet cabling power losses not included. Losses range from being negligible for short Cat5/6 cables, up to about 16% for 100 meter Cat5/6 cables.	

To meet the Reader Controller's variable PoE power requirements, the Reader Controller will classify itself with the PoE source as a "Class 0" PoE device. The power usage of a Class 0 device can range between 0.4 to 13.0 watts at the device (up to 15.4 watts from the PoE source).

Some network PoE equipment will budget and allocate its distribution of PoE power based upon the maximum power usage of the each attached device's classification. If your network equipment uses this power provisioning technique, then you should budget 15.4 watts for each Reader Controller. Such network PoE Equipment may allow you to manually configure the amount of power that should be allocated to each device. Configuring the PoE equipment for an allocation of 3.0 watts or 11.0 watts per connection would be appropriate. When powering from PoE or PoE+, in order for the system to be UL294 V7 compliant, the PoE injector or end point must be compliant to UL294 or UL294B standards.

Using PoE over longer cable distances:

The Reader Controller can be powered via PoE on cable runs up to 328' (100 m) long (the standard Ethernet cable limit).

For Reader Controller locations that have longer cable runs (> 164' [50 m]), extra care should be given to the planning and installation of the network cabling. The PoE power delivery system will running at about 80% of the allowable capacity, when powering a 600mA lock over a 100 meter cable run.

For these long cable run installations, here are some items to focus on:

- Cabling:
 - Use high-quality Ethernet cabling (Cat 5e or Cat6). Please note that the power loss over a Cat 6 cable is about 30% less than the power loss on a Cat5e cable
 - Cable Length. The 100 meter limit needs to include any patch cords and patch panels.
 - Follow IEEE/TIA installation best practices.
- PoE Source
 - The PoE Source (PoE Network switch or PoE Injector) meets the IEEE 802.3af standard.
 - The PoE Source is properly sized to supply 15.4 watts/port. (Cabling power losses can be up to 2.5 watts/cable)

Additional power options

Most installations will use PoE for the Reader Controller and door locks to control a door using a single, standard network cable. There are many additional options available if the door location requires more power than a standard PoE-powered Reader Controller can provide.

The different options require different configurations of the supporting equipment and/or building wiring. **Table 4.2: Power option configurations** and **Figure 4.1: Power options** describes some of these power options.

Table 4.2: Power option configurations				
Power Source	Switchable Power (Max)	Equipment at the Door	Limiting Factor	Dia.
PoE (802.3af)	0.60 amps (12VDC)	Reader controller	Reader controller's available PoE Output	A
PoE (802.3af)	0.55 amps (12VDC)	Reader controller ASM	Reader controller's available PoE Output {minus} the power required by the ASM	B
DC Power Supply 12 VDC	3.0 amps (12VDC)	Reader controller ASM	Rating of ASM's lock relay (12VDC required by ASM's internal circuitry)	C
PoE Plus (802.3at)	1.8 amps (Approx) (12VDC)	Reader controller ASM PoE Splitter Example: PoE Splitter PowerDsine PD-AS-701/12	Rating of PoE Splitter {minus} power required to operate Reader Controller & ASM	D
High-Powered PoE (non-standard) Example: PoE Injector PowerDsine PD-9501G	3.0 amps (12VDC)	Reader controller ASM PoE Splitter Example: PoE Splitter PowerDsine PD-AS-951/12-24	Rating of ASM's lock relay	E

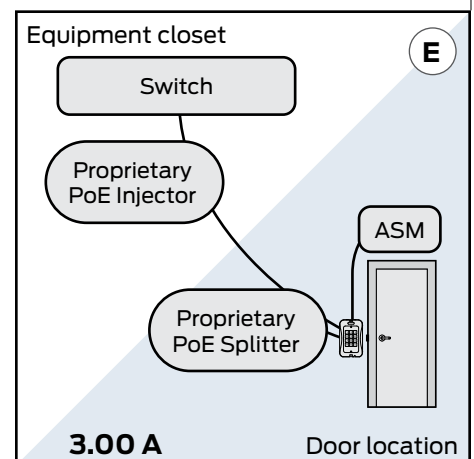
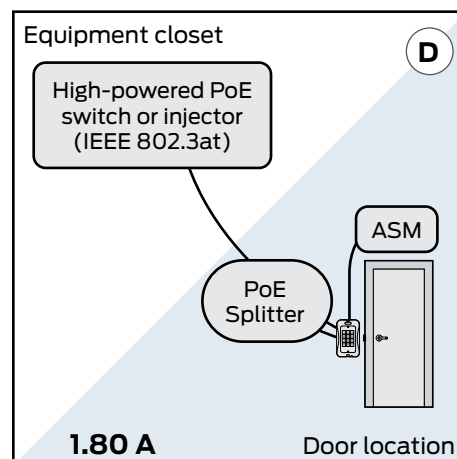
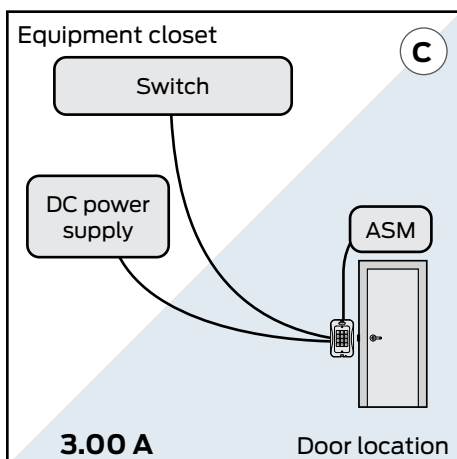
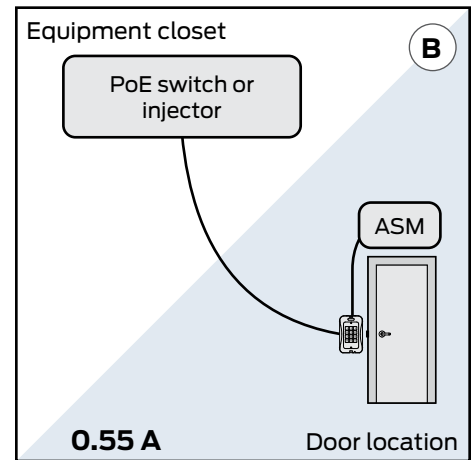
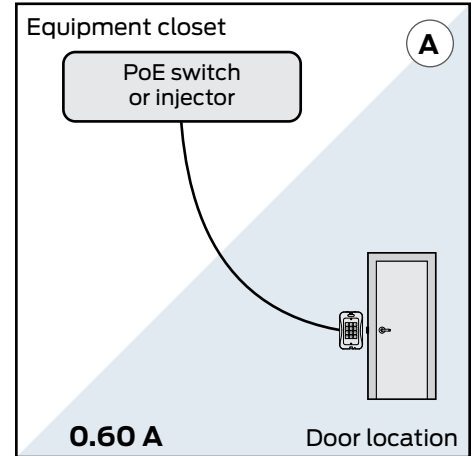

Figure 4.1: Power options

Dual power sources

Typical Reader Controller install with:

- Redundant power supplies
- Input power: PoE
- Input power: 12VDC

Solution highlights

- Improve the ACS fault-tolerance design by supplying the Reader Controller with electrical power from two independent power sources.
- With this design, if the Reader Controller's connection to the PoE network switch is lost, the Reader Controller will automatically begin to draw its power from the DC power source.

Installation tips

- Schottky Diode:
 - Manufacturer: Vishay/General Semiconductor
 - P/N: SB560-E3/54 or equivalent
 - Install the BackEMF diode
 - Red wire will provide the lock with +12VDC

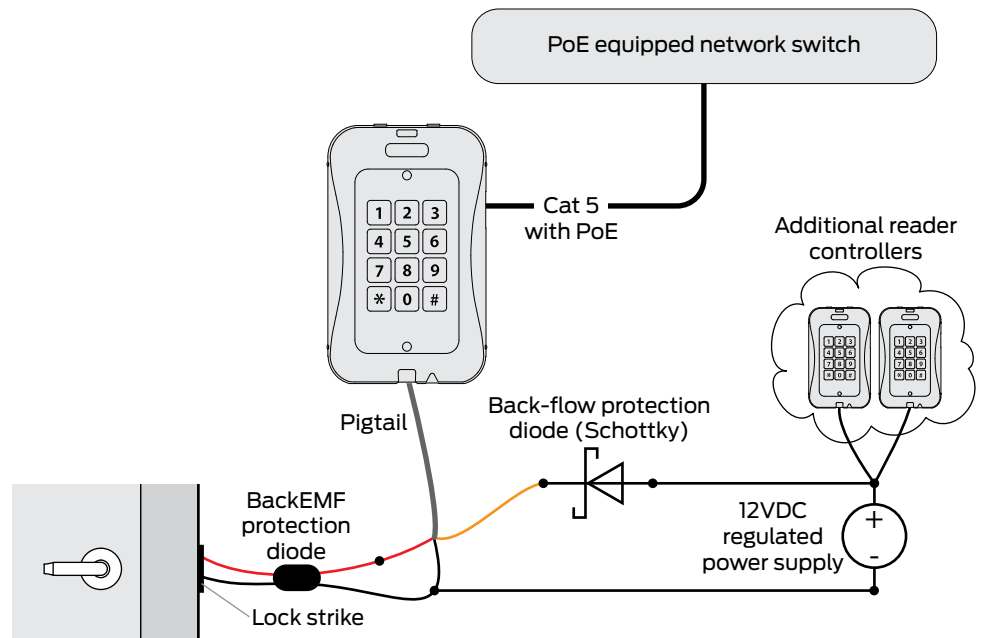

Figure 4.2: Dual power sources wiring

Appendix B: Additional wiring considerations

ASM LED status index

The ASM has two status LEDs

Power LED:

Located on the side towards the Reader Controller's field wiring.

A Red LED indicates 12VDC power is being supplied to the ASM.

Communication Status LED:

Located on the side towards the Lock wiring.

LED status meaning are described in the table below.

Reader controller Locked	Reader controller Unlocked	Lock State when Reader controller is unlocked	Description or Item to Check
Off	Green	Normal Operation	
Flash Amber	Flash Amber	No Operation	Yellow wire may be disconnected
Off	Flash Amber	No Operation	White wire may be disconnected
Off	Flash Amber	No Operation	Invalid encryption key received from Reader Controller
Off	Off	No Operation	If PowerCycle of Reader Controller allows for one or more lock operations, and then the lock stops operating, then the BackEMF diode may not be installed correctly.

Wiring two readers to one lock

If you are wiring both sides of the door to control IN and OUT access, then you will have the special condition of wiring two reader controllers to a single locking mechanism.

The "Inside" Reader Controller controls the door, and is wired to the door's components, such as the lock and door-sense switch. Use the following steps to cause the "outside" Reader Controller to activate the REX input on the "Inside" Reader Controller.

Steps

→ Figure 5.1: Two readers to one lock wiring

1. Wire the "Inside" reader normally
2. Connect an ASM to the "Outside" reader
3. Connect the "Inside" reader's REX input to the "NO" terminal of the ASM.
4. Connect the "Inside" reader's black wire to the Common terminal of the ASM.
5. If the door also has a REX device, wire the REX device "in parallel" to the ASM.

Programming

"Inside" Reader Controller must be programmed to activate the lock upon a REX input event.

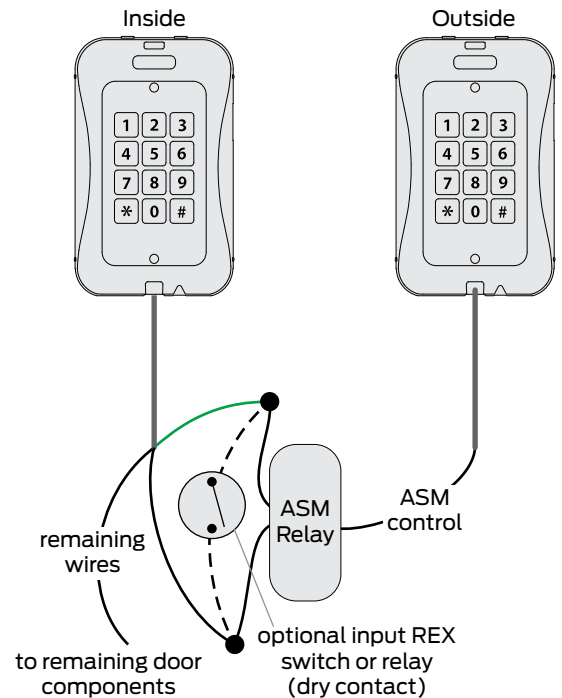

Figure 5.1: Two readers to one lock wiring

Managing inductive load challenges

Most door latches use a relay coil that powers up and down, when the door is unlocked and locked. When this happens, a pulse of electrical energy is produced by the lock's coil. This pulse is called back EMF, and can interfere with the reader's operation.

Switching off a typical 12 VDC relay coil can produce a back EMF pulse of 300 volts or more. If this voltage pulse is allowed to flow back into the reader, it can cause the reader to "brown out" and the reader will reboot.

Figure 5.2: Inductive load control (two options shown) shows a solution. You can virtually eliminate back EMF by installing a transient suppression device (diode). Each Reader Controller is supplied with a diode assembly, which simplifies the installation process. A standard diode, from any electronic supply store, can also be used. Always check that the diode is correctly rated for the circuit voltage. For optimum performance, the diode should be installed at the lock or close to the lock. Standard diodes have a stripe-band marking on one side. That side of the diode should be connected to the "+" wire of the lock circuit.

Protect the Digital Output

Which type of transient suppressor should you install? This depends mainly on the type of inductive load being switched. Some locks have Back EMF protection built into the lock itself.

For Back EMF in low voltage DC applications, a 1N4007 diode will suffice.

However, for protection against other transient voltages (i.e. lightning), we recommend using a fast-switching transient voltage suppressor.

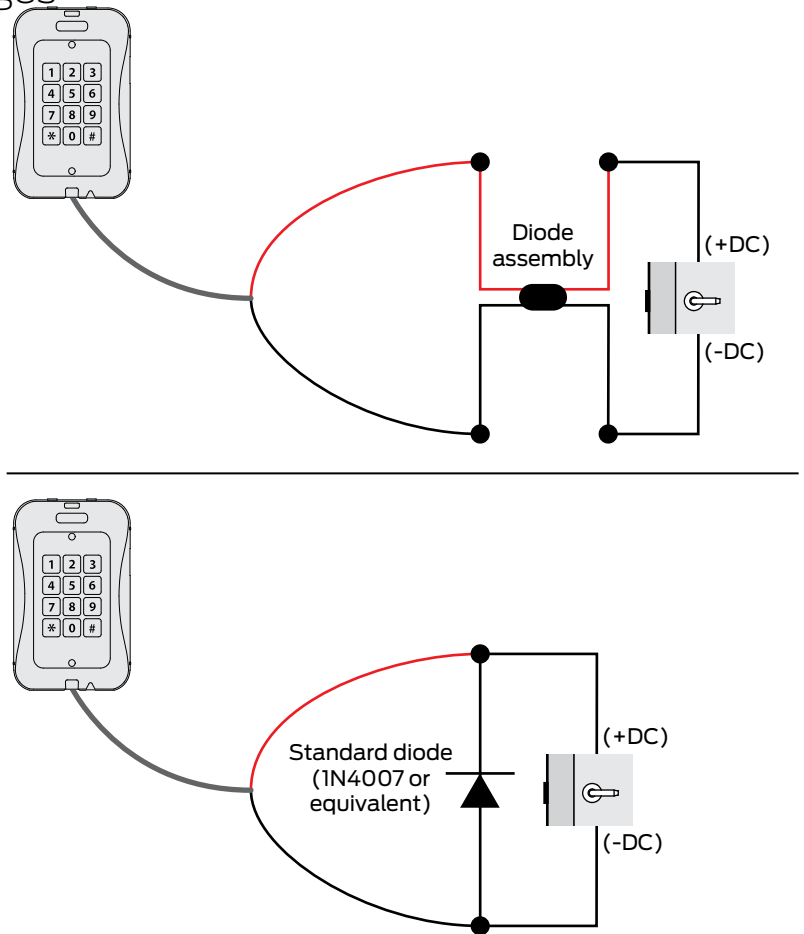

Figure 5.2: Inductive load control (two options shown)

PoE: Magnetic lock, ASM and PIR

Typical Reader Controller install with:

- Magnetic lock
- ASM
- PIR motion detector
- In-rush supressor
- Door open sensor
- PoE splitter
- Input power
 - PoE to the PoE splitter
 - 12VDC from splitter to components

Installation tips

- PoE splitter and fuse isolated the magnetic lock's power source to the inside of the facility
- See **Advanced Security Module (ASM) wiring** on page 14 for more information.
 - Splitter 12V to ASM power input and ASM relay common contact
- ACC-IRS-4700 - Red wire goes to the 12V supply (PoE splitter)
- 0.5 Amp fast-acting fuse: Littelfuse PN: 0208.500MXP or equivalent
- In-line fuse- holder: Littelfuse PN: 150274 or equivalent

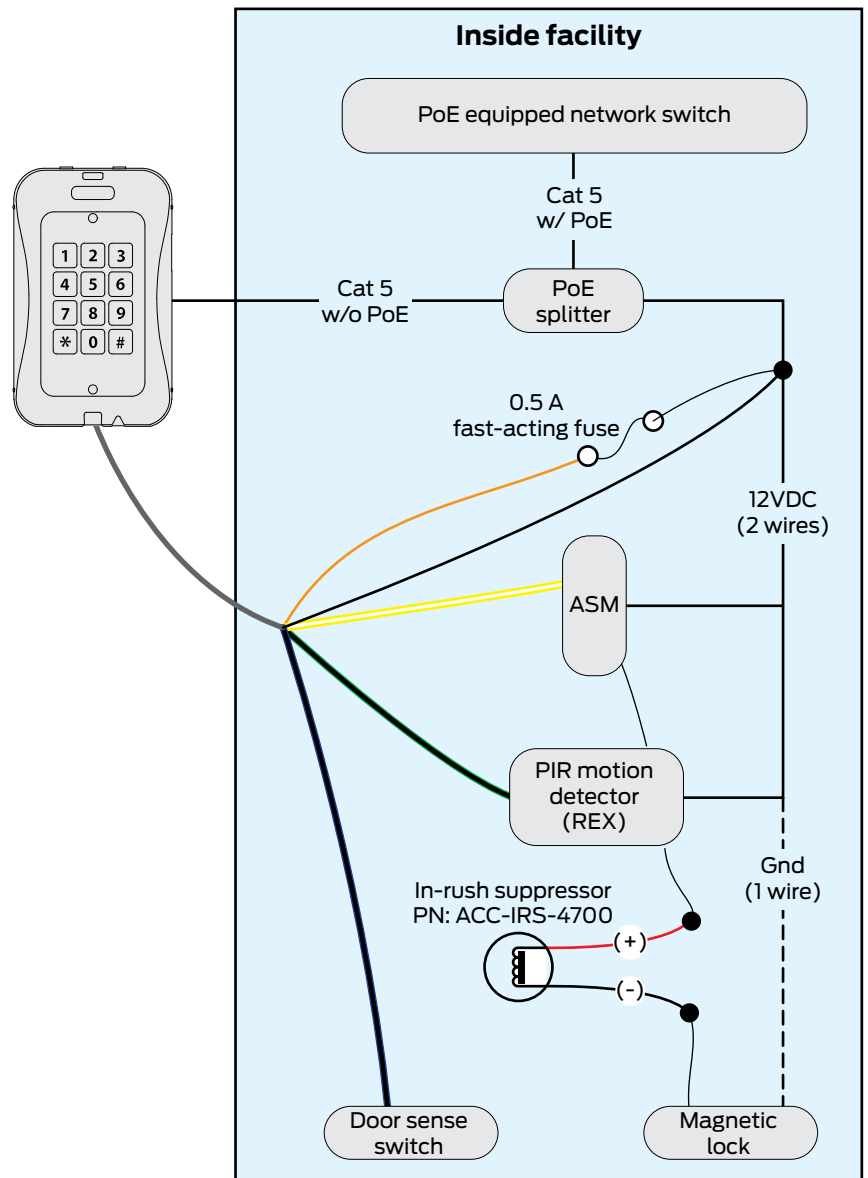

Appendix C: UL Disclaimers

- Electronic credential transmission technology: Bluetooth (BGM111) Version 02.11.01.241, 01.08.04, 01-1.6.0 or greater.
- Reader controller main firmware version 1.1.46 or greater and bootloader version 11.04.00 or greater.
- Wireless electronic credential application: Schlage Mobile Access version 1.0.0 or greater.

The access control system shall have the means to distinguish between the type of credential used via code or description (i.e. authentication/digital signature keys received from a physical card vs. authentication/digital signature keys received from a wireless electronic credential).

When provided, minimum data encryption/authentication techniques shall be employed in accordance with paragraph 64.3.2 in the UL 294 standard.

The wireless electronic credential was only used as an alternate means for transmitting the user data typically found on a physical credential to the reader interface. The wireless electronic device shall not be capable of command, control, programming, or any other system manipulation.

The wireless electronic device shall only be used in the same manner as a physical credential, transmitting user data to the reader interface within close proximity, as indicated by the manufacturer.

About Allegion™

At Allegion (NYSE: ALLE), we design and manufacture innovative security and access solutions that help keep people safe where they live, learn, work and connect. We're pioneering safety with our strong legacy of leading brands like CISA®, Interflex®, LCN®, Schlage®, SimonsVoss® and Von Duprin®. Our comprehensive portfolio of hardware, software and electronic solutions is sold around the world and spans residential and commercial locks, door closer and exit devices, steel doors and frames, access control and workforce productivity systems. Allegion had \$3.8 billion in revenue in 2024.

For more, visit www.allegion.com.

